

Introduction to Switched- Mode Power Supply (SMPS) Circuits

1.1 Introduction to regulated dc power supplies

Power supply is a broad term but this lesson is restricted to discussion of circuits that generate a fixed or controllable magnitude dc voltage from the available form of input voltage. Integrated-circuit (IC) chips used in the electronic circuits need standard dc voltage of fixed magnitude. Many of these circuits need well-regulated dc supply for their proper operation. In majority of the cases the required voltages are of magnitudes varying between -9 to +9 volts. Some equipment may need **multiple output power supplies**. For example, in a Personal Computer one may need 3.3 volt, ± 5 volt and ± 9 volt power supplies. The digital ICs may need 3.3volt supply and the hard disk driver or the floppy driver may need ± 5 and ± 9 volts supplies. The individual output voltages from the multiple output power supply may have different current ratings and different voltage regulation requirements. Almost invariably these outputs are **isolated dc voltages** where the dc output is ohmically isolated from the input supply. In case of multiple output supplies ohmic isolation between two or more outputs may be desired. The input connection to these power supplies is often taken from the standard utility power plug point (ac voltage of 115V / 60Hz or 230V / 50Hz). It may not be unusual, though, to have a power supply working from any other voltage level which could be of either ac or dc type.

There are two broad categories of power supplies: **Linear regulated power supply** and **switched mode power supply (SMPS)**. In some cases one may use a combination of switched mode and linear power supplies to gain some desired advantages of both the types.

1.2 Linear regulated power supply

Fig. A the basic block for a linear power supply operating from an unregulated dc input. This kind of unregulated dc voltage is most often derived from the utility ac source. The utility ac voltage is first stepped down using a utility frequency transformer, then it is rectified using diode rectifier and filtered by placing a capacitor across the rectifier output. The voltage across the capacitor is still fairly unregulated and is load dependent. The ripple in the capacitor voltage is not only dependent on the capacitance magnitude but also depends on load and supply voltage variations. The unregulated capacitor voltage becomes the input to the linear type power supply circuit. The filter capacitor size is chosen to optimize the overall cost and volume. However, unless the capacitor is sufficiently large the capacitor voltage may have unacceptably large ripple. The representative rectifier and capacitor voltage waveforms, where a 100 volts (peak), 50 Hz ac voltage is rectified and filtered using a capacitor of 1000 micro-farad and fed to a load of 100 ohms is For proper operation of the voltage regulator, the instantaneous value of unregulated input voltage must always be few volts more than the desired regulated voltage at the output. Thus the ripple across the capacitor voltage (difference between the maximum and minimum instantaneous magnitudes) must not be large or else the minimum voltage level may fall below the required level for output voltage regulation. The magnitude of voltage-ripple across the input capacitor increases with increase in load connected at the output.

The step down transformer talked above should be chosen such that the peak value of rectified voltage is always larger than the sum of bare minimum voltage required at the input of the regulator and the worst-case ripple in the capacitor voltage. Thus the transformer turns ratio is chosen on the basis of minimum specified supply voltage magnitude. The end user of the power supply will like to have a regulated output voltage (with voltage ripple within some specified range) while the load and supply voltage fluctuations remain within the allowable limit. To achieve this the unregulated dc voltage is fed to a voltage regulator circuit. The circuit in Fig.A shows, schematically, a linear regulator circuit where a transistor is placed in between the unregulated dc voltage and the desired regulated dc output. Difference between the instantaneous input voltage and the regulated output voltage is blocked across the collector - emitter terminals of the transistor. As discussed previously, in such circuits the lowest instantaneous magnitude of the unregulated dc voltage must be slightly greater than the desired output voltage (to allow some voltage for transistor biasing circuit). The power dissipation in the transistor and the useful output power will be in the ratio of voltage drops across the transistor and the load (here the control power dissipated in the base drive circuit of the transistor is assumed to be relatively small and is neglected). The worst-case series voltage drop across the transistor may be quite large if the allowed variation in supply magnitude is large. Worst-case power dissipation in the transistor will correspond to maximum supply voltage and maximum load condition (load voltage is assumed to be well regulated). Efficiency of linear voltage regulator circuits will be quite low when supply voltage is on the higher side of the nominal voltage.

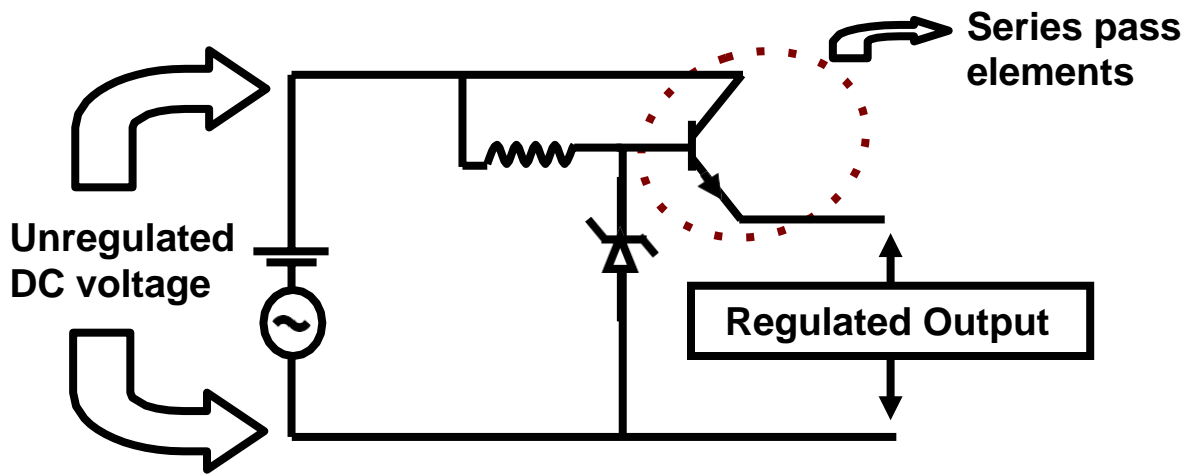

Fig. A: Schematic linear voltage regulator

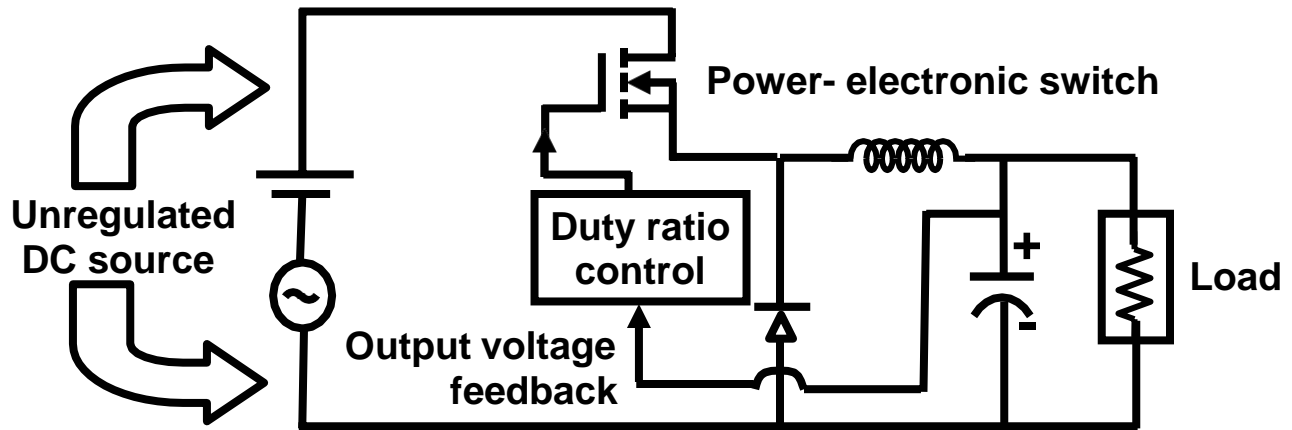

Fig. B: A schematic switched mode dc to dc chopper circuit

Problem 1

An 18V (rms), 50 Hz supply is rectified using a full bridge diode rectifier and is followed by a capacitor filter. The load connected across the capacitor is a simple resistor of 30 ohm. What should be the value of filter capacitor to get only 5 volts peak to peak ripple across the load voltage? Neglect voltage drop across conducting diode.

[Hint: The exact solution will involve use of numerical technique or trial and error method. However with some simplifying assumptions, fairly accurate value of capacitance may be found out. It may be assumed that in each half cycle the capacitor charges to the peak of supply voltage (= $18 \times 1.414 = 25.456$ volts). The ripple in the capacitor voltage may be neglected to calculate load current. Thus capacitor may be assumed to discharge under the influence of $25.456/30$ amp. (I) for a time duration ($\otimes t$) equal to $\frac{\pi - \cos^{-1} \frac{25.456 - 5}{18}}{2\pi(\text{freq.})}$. Next, use the equality

$$C \otimes V = I \otimes t \text{ and find } C$$

Answer: C = approx. 1350 microfarad.]

Problem 2

It is desired to get a regulated 15 volts supply from the utility ac voltage of 50 Hz using a linear regulator circuit. The input ac voltage (rms magnitude) varies from 190 volts to 260volts. The utility voltage is first stepped down using a transformer. The stepped down voltage is rectified using a diode bridge and filtered by placing a capacitor after the rectified output. Assuming peak-to-peak ripple in the capacitor voltage to be 10% of the capacitor's crest voltage, find the turns ratio of the step down transformer. For proper operation of the linear regulator circuit the input voltage applied to it must always be 2 volts more than the desired output voltage (neglect diode drops).

[Answer: Turns ratio = L.V. turns/ H.V. turns = $\{ 1.11 (15+2) \} / (190 * 1.414) = 1 : 14$]

1.3 Switched Mode Power Supply (SMPS)

Like a linear power supply, the switched mode power supply too converts the available unregulated ac or dc input voltage to a regulated dc output voltage. However in case of SMPS with input supply drawn from the ac mains, the input voltage is first rectified and filtered using a capacitor at the rectifier output. The unregulated dc voltage across the capacitor is then fed to a high frequency dc-to-dc converter. Most of the dc-to-dc converters used in SMPS circuits have an intermediate high frequency ac conversion stage to facilitate the use of a high frequency transformer for voltage scaling and isolation. In contrast, in linear power supplies with input voltage drawn from ac mains, the mains voltage is first stepped down (and isolated) to the desired magnitude using a mains frequency transformer, followed by rectification and filtering. The high frequency transformer used in a SMPS circuit is much smaller in size and weight compared to the low frequency transformer of the linear power supply circuit.

The 'Switched Mode Power Supply' owes its name to the dc-to-dc switching converter for conversion from unregulated dc input voltage to regulated dc output voltage. The switch employed is turned 'ON' and 'OFF' (referred as switching) at a high frequency. During 'ON' mode the switch is in saturation mode with negligible voltage drop across the collector and emitter terminals of the switch where as in 'OFF' mode the switch is in cut-off mode with negligible current through the collector and emitter terminals. On the contrary the voltage-regulating switch, in a linear regulator circuit, always remains in the active region.

Details of some popular SMPS circuits, with provisions for incorporating high frequency transformer for voltage scaling and isolation, have been discussed in next few lessons. In this lesson a simplified schematic switching arrangement is described that omits the transformer action. In fact there are several other switched mode dc-to-dc converter circuits that do not use a high frequency transformer. In such SMPS circuits the unregulated input dc voltage is fed to a high frequency voltage chopping circuit such that when the chopping circuit (often called **dc to dc chopper**) is in ON state, the unregulated voltage is applied to the output circuit that includes the load and some filtering circuit. When the chopper is in OFF state, zero magnitude of voltage is applied to the output side. The ON and OFF durations are suitably controlled such that the average dc voltage applied to the output circuit equals the desired magnitude of output voltage. The ratio of ON time to cycle time (ON + OFF time) is known as duty ratio of the chopper circuit. A high switching frequency (of the order of 100 KHz) and a fast control over the duty ratio results in application of the desired mean voltage along with ripple voltage of a very high frequency to the output side, consisting of a low pass filter circuit followed by the load. The high

frequency ripple in voltage is effectively filtered using small values of filter capacitors and inductors. A schematic chopper circuit along with the output filter is shown in **Fig.21.3**. Some other switched mode power supply circuits work in a slightly different manner than the dc-to-dc chopper circuit discussed above. Details of some of these circuits have been discussed in following lessons.

1.4 SMPS versus linear power supply

As discussed above, in a linear regulator circuit the excess voltage from the unregulated dc input supply drops across a series element (and hence there is power loss in proportion to this voltage drop) whereas in switched mode circuit the unregulated portion of the voltage is removed by modulating the switch duty ratio. The switching losses in modern switches (like: MOSFETs) are much less compared to the loss in the linear element.

In most of the switched mode power supplies it is possible to insert a high frequency transformer to isolate the output and to scale the output voltage magnitude. In linear power supply the isolation and voltage-scaling transformer can be put only across the low frequency utility supply. The low frequency transformer is very heavy and bulky in comparison to the high frequency transformer of similar VA rating. Similarly the output voltage filtering circuit, in case of low frequency ripples is much bulkier than if the ripple is of high frequency. The switched mode circuit produces ripple of high frequency that can be filtered easily using smaller volume of filtering elements.

Linear power supply though more bulky and less efficient has some advantages too when compared with the switched mode power supply. Generally the control of the linear power supply circuit is much simpler than that of SMPS circuit. Since there is no high frequency switching, the switching related electro-magnetic interference (EMI) is practically absent in linear power supplies but is of some concern in SMPS circuits. Also, as far as output voltage regulation is concerned the linear power supplies are superior to SMPS. One can more easily meet tighter specifications on output voltage ripples by using linear power supplies.

Problem 3

Estimate and compare the size (window area X core area) of the following two transformers: (i) a 50 VA, 50Hz, 15V low frequency transformer and (ii) a 50 VA, 100 kHz, 15V high frequency transformer. Assume sinusoidal voltages. Assume the peak flux density in low frequency transformer to be 1.5 tesla and in high frequency transformer to be 0.3 tesla. Take identical values for window utilization factor and copper current density.

[Hint: VA rating for a single phase transformer = $2.22 f B_{\max} A_C A_W \delta K_W$, where f is supply frequency, B_{\max} is the peak flux density, A_C : core area, A_W : window area, δ : current density in copper and K_W is the window utilization factor.]

Answer: Volume (size) of Low frequency transformer will be 400 times higher than that of high frequency transformer.

1.5 Hybrid (SMPS followed by linear) power supply

A comparison of linear and switched mode power supplies tells about the advantages and disadvantages of the two. Linear power supply is highly inefficient if it has to work over large variations in input voltage, is more bulky because of the use of low frequency transformer and filter elements (inductors and capacitors). On the other hand linear power supplies give better output voltage regulation. It may sometimes be required to have output voltage regulation similar to the one provided by linear supplies and compactness and better efficiency of a switched mode supply. For this, the linear power supply may be put in tandem with a switched mode supply. Let us consider a case where one needs an isolated and well-regulated 5 volts output while input power is drawn from utility supply that has large voltage fluctuation. In such a situation one may generate an isolated 7.5 volts from an SMPS and follow it by a 5 volts linear power supply set to work with 7.5 volts input. The input to linear power supply must be few volts more than the required output (for proper biasing of the switches) and hence SMPS tries to maintain around 7.5 volts input. It can be seen that the linear power supply now does not have large input voltage variation in spite of large variations in the utility rms voltage. The SMPS portion of the power supply efficiently performs the job of voltage isolation and conversion from widely varying utility voltage to fairly regulated 7.5 volts dc. Under the given condition it may not be difficult to see that the overall efficiency of this hybrid power supply will lie between that of a SMPS and a linear supply. The overall cost may or may not increase even though two supplies in tandem are used. It is to be kept in mind that to achieve the same output voltage specification by an SMPS circuit alone, the control and filtering circuit may become more costly and complex (than the one used in the hybrid power supply unit). Similarly if the linear supply has to be designed for larger fluctuation in input voltage the component ratings, including heat-sink ratings, will be higher and may cost as much as the hybrid unit.

1.6 Multiple output SMPS

A single power supply unit may need to output several different voltages. The individual output voltages may have different ratings in terms of output current, voltage regulation and ripple voltages. These outputs may need isolation between them. Generally a common high frequency transformer links the input and output windings and in spite of output voltage feedback all the outputs cannot have same regulation because of different loads connected to different outputs and hence different ohmic (resistive) drops in the output windings (loads are generally variable and user dependent). Also the coupling between the different secondary windings and the primary winding may not be same causing different voltage drops across the respective leakage inductances. Barring this mismatch in the voltage drops across the resistances and leakage inductances of the secondary windings their output voltages are in proportional to their turn's ratios. The turns ratios are properly chosen to give fairly regulated individual output voltages (even if only one output voltage feedback is used for SMPS switch control). The output that needs to have tighter voltage regulation may be used for output voltage feedback. In case another output needs to have similarly tight regulation then that particular output may be passed through an additional linear regulator circuit as in the case of hybrid power supply circuit discussed in the previous section (Sec. 21.5).

1.7 Resonant Mode Power Supplies

Resonant mode power supplies are a variation over SMPS circuits where the switching losses are significantly reduced by adapting zero-voltage or zero-current switching techniques. In non-resonant mode SMPS circuits the switches are subjected to hard switching (during hard-switching, both the voltage and current in the switch are of considerable magnitude resulting in large instantaneous switching power loss). Efficiency of resonant mode power supplies is generally higher than non-resonant mode supplies.

1.8 Power supply specifications

Power supplies may have several specifications to be met, including their voltage and current ratings. There may be short time ratings of higher magnitudes of current and continuous ratings of somewhat lower magnitudes. One needs to specify the tolerable limits on the ripple voltages, short-circuit protection level of current (if any) and the nature of output volt-current curve during over-current or short circuit (the output voltage magnitude should reduce or fold back towards zero, gradually, depending on the severity of over-current). The fuse requirement (if any) on the input and the output side may need to be specified. One needs to specify the type of input supply (whether ac or dc) or whether the power supply can work both from ac or dc input voltages. Acceptable range of variation in input voltage magnitude, supply frequency (in case of ac input) are also to be specified. Efficiency, weight and volume are some other important specifications. Some applications require the electro-magnetic compatibility standards to be met. By electromagnetic compatibility it is meant that the level of EMI generation by power supply should be within tolerable limits and at the same time the power supply should have the ability to work satisfactorily in a limited noisy environment. It is quite common to have output voltage isolation and it is specified in terms of isolation breakdown voltage. In case of multiple power supplies it needs to be specified whether all the outputs need to be isolated or not and what should be the acceptable ripple voltage range for each.

In majority of the cases the available source of input power is the alternating type utility voltage of 50 or 60 Hz. The voltage levels commonly used are 115V (common in countries like, USA) and 230 volts (common in India and many of the European countries). Most utility (mains) power supplies are expected to have $\pm 10\%$ voltage regulation but for additional precaution the SMPS circuits must work even if input voltages have $\pm 20\%$ variation. Now-a-days universal power supplies that work satisfactorily and efficiently both on 115 V and 230 V input are quite popular. These power supplies are very convenient for international travelers who can simply plug-on their equipments, like laptop computer and shaving machine, without having to pay much attention on the exact voltage and frequency levels of the utility supply. In contrast some of the other power supplies have a selector switch and the user is required to adjust the switch position to match the utility voltage. In case user forgets to keep the selector switch at correct position, the equipment attached may get damaged.

1.9 Some common types of SMPS circuits

There are several different topologies for the switched mode power supply circuits. Some popular ones are: fly-back, forward, push-pull, C'uk, Sepic, half bridge and H-bridge circuits. Some of these configurations will be discussed in the coming lessons. A particular topology may be more suitable than others on the basis of one or more performance criterions like cost,

efficiency, overall weight and size, output power, output regulation, voltage ripple etc. All the topologies listed above are capable of providing isolated voltages by incorporating a high frequency transformer in the circuit. There are many commercially available power supply controller ICs that can readily be used to control the duty ratio of the SMPS switches so that the final output is well regulated. Most of these ICs are capable of driving MOSFET type of switches. They also provide features like under voltage lock-out, output over-current protection etc.

Problem 4

Which among the following power supplies will be most energy-efficient if operated under wide input voltage variation and at full load:

- (i) Linear power supply
- (ii) Switched mode power supply
- (iii) Switched mode followed by linear power supply
- (iv) Linear followed by switched mode power supply

Answer: (ii)

More Quiz problems on Chapter-21

- (1) A regulated power supply should be able to maintain output voltage within specified limits in spite of
 - (a) Unlimited variation in supply voltage
 - (b) Unlimited variation in load at the output
 - (c) Both (a) and (b)
 - (d) Only for load and supply parameter- variations in the specified range
- (2) Linear isolated power supplies will generally be superior to switched-mode power supplies (outputting isolated voltage) in respect to the following
 - (a) Higher efficiency in the entire range of load and supply variations
 - (b) Better dynamic regulation of output voltage against supply variations
 - (c) Less volume and weight for identical input and output ratings
 - (d) All the above
- (3) High frequency transformers are used for output voltage isolation and scaling in the following type of power supplies:-
 - (a) Switched mode power supplies
 - (b) Linear power supplies
 - (c) Hybrid power supplies
 - (d) Both (a) and (c)
- (4) A 60watt, $15V \pm 0.2V$, power supply specified to deliver regulated output for input supply (50Hz) variation from 180 volts to 270 volts will be different from another power supply with identical output rating but capable of outputting regulated voltage over input range of 90 volts to 270 volts in respect of:-
 - (a) Less cost
 - (b) More bulky and more costly
 - (c) Higher current rating of power-switch
 - (d) None of the above

Answers: (1-d), (2-b), (3-d), (4-a)